

BRACE STRUT DETAILS

- AK0050 - PIPE OR BOX STRUT AT COLUMN/RAFTER FLANGE
 - AK0090 - BRACING DETAIL AT STRUT WITH FLANGE CONNECTION
 - AK0160 - 2-BOLT 6" PIPE OR BOX STRUT AT WEB OF COLUMN/RAFTER (8" MIN. COLUMN/RAFTER)
 - AK0161 - 2-BOLT 6" PIPE OR BOX STRUT AT WEB OF COLUMN/RAFTER (WITH LINERS AND 11" MIN. COLUMN/RAFTER)
 - AK0165 - 2-BOLT 6" PIPE OR BOX STRUT AT WEB OF COLUMN/RAFTER (WITH PADDLE BRACE)
 - AK0166 - 2-BOLT 6" PIPE OR BOX STRUT WITH TIERED PADDLE BRACING (STIFFENER CONNECTION)
 - AK0167 - 2-BOLT 6" PIPE OR BOX STRUT AT WEB WITH PADDLE BRACE (WITH LINER AT STIFFENER CONNECTION)
 - AK0170 - 3-BOLT 6"/8" PIPE STRUT AT COLUMN/RAFTER (STIFFENER CONNECTION WITH 10" MIN. COLUMN/RAFTER)
 - AK0175 - 3-BOLT 6"/8" PIPE STRUT AT WEB OF COLUMN/RAFTER (STIFFENER WITH PADDLE BRACE)
 - AK0176 - 3-BOLT 6"/8" PIPE STRUT WITH TIERED PADDLE BRACING (STIFFENER CONNECTION)
 - AK0177 - 2-BOLT STRUT AT 8" ENDWALL (6" PIPE OR BOX CEE STRUT)
 - AK0300 - STRUT PURLIN DETAIL
-

AK0050 - PIPE OR BOX STRUT AT COLUMN/RAFTER FLANGE

[Download the DWG file by clicking here.](#)

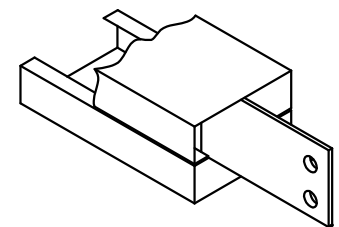
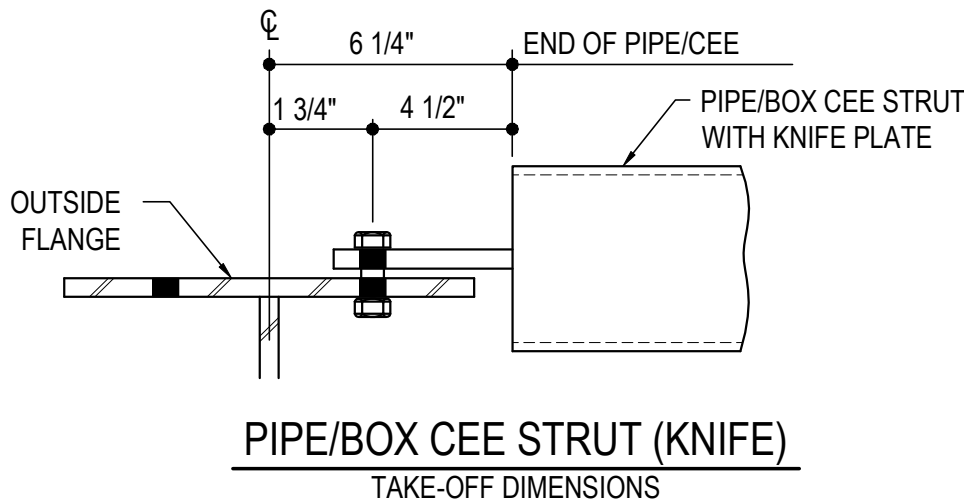
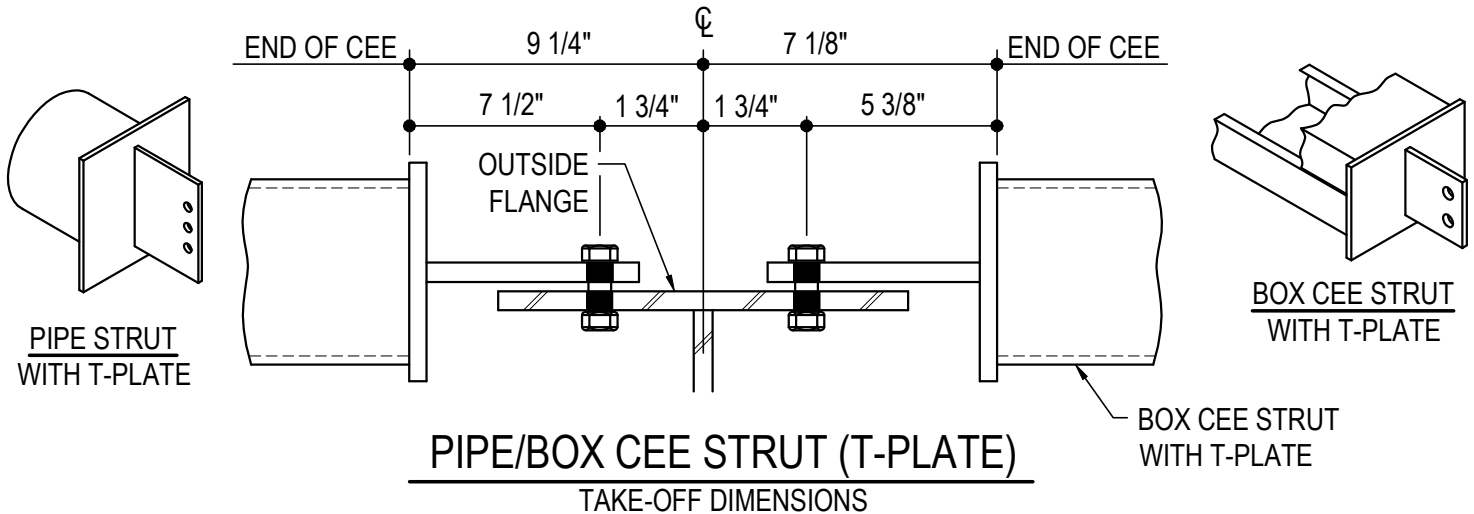

BOX CEE STRUT WITH KNIFE PLATE

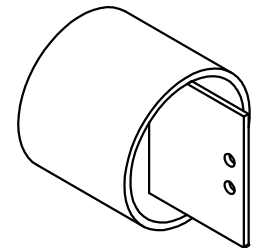

PIPE STRUT WITH KNIFE PLATE

- ON A 6" STRUT USE (2) 1" X 3 1/4" A325 BOLTS H0640/NUTS H0330
- ON A 8" STRUT USE (3) 1" X 3 1/4" A325 BOLTS H0640/NUTS H0330
- ON A 6"/8" T-PLATE STRUT USE (3) 1" X 3 1/4" A325 BOLTS H0640/NUTS H0330
- ON A BOX CEE STRUT USE (2) 1" X 3 1/4" A325 BOLTS H0640/NUTS H0330

PIPE OR BOX STRUT AT COLUMN/RAFTER FLANGE

SEE PLANS & ELEVATIONS FOR MARK NUMBERS AND LOCATIONS
REFERENCE ERECTOR NOTE FOR TYPICAL WASHER REQUIREMENTS

AK0050

Detailer Notes:
1) N/A

AK0090 - BRACING DETAIL AT STRUT WITH FLANGE CONNECTION

[Download the DWG file by clicking here.](#)

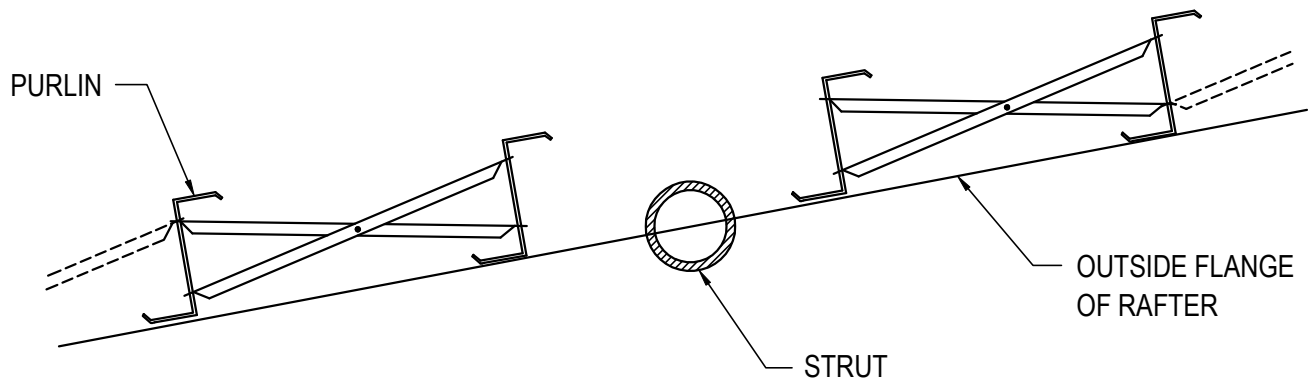

USE THIS DETAIL WHEN STRUT BOLTS TO RAFTER FLANGE
TO AVOID INTERFERENCE WITH PURLIN BRACING.
(REFERENCE STD. PURLIN BRACE DETAILS)

BRACING DETAIL AT STRUT WITH FLANGE CONNECTION

AK0090

Detailer Notes:

- 1) N/A

AK0160 - 2-BOLT 6" PIPE OR BOX STRUT AT WEB OF COLUMN/RAFTER (8" MIN. COLUMN/RAFTER)

[Download the DWG file by clicking here.](#)

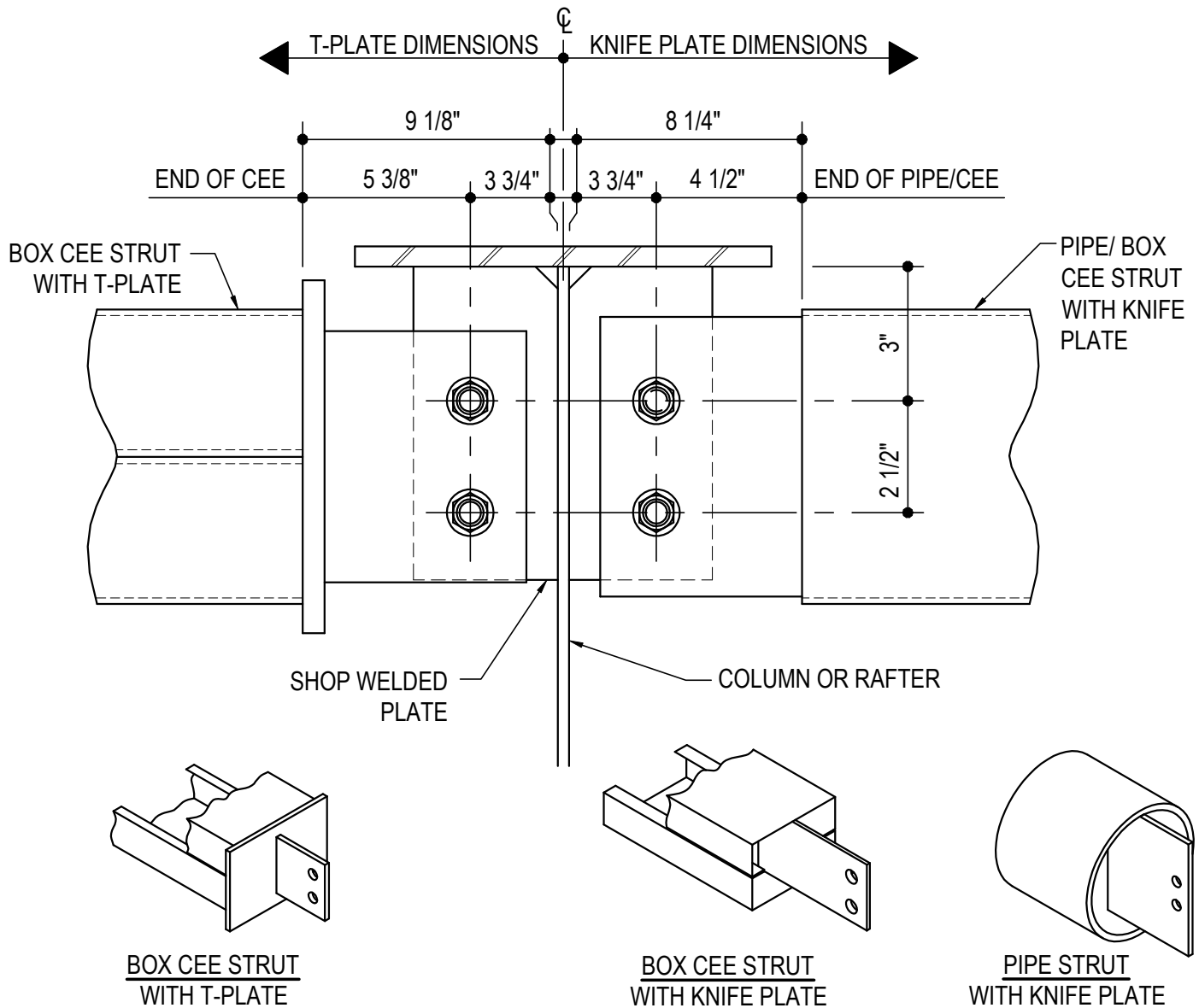

NOTE: USE (2) 1" X 3 1/4" A325 BOLTS H0640/NUTS H0330

2-BOLT 6" PIPE OR BOX STRUT AT WEB OF COLUMN/RAFTER

8" MIN. COLUMN/RAFTER
SEE PLANS & ELEVATIONS FOR MARK NUMBERS AND LOCATIONS

AK0160

Detailer Notes:

- 1) FOR PSC STANDARD PART MARKS AND THEIR LOCATIONS, SEE THE FABRICATED PARTS MANUAL AND THE DETAILING PROCEDURES MANUAL

AK0161 - 2-BOLT 6" PIPE OR BOX STRUT AT WEB OF COLUMN/RAFTER (WITH LINERS AND 11" MIN. COLUMN/RAFTER)

[Download the DWG file by clicking here.](#)

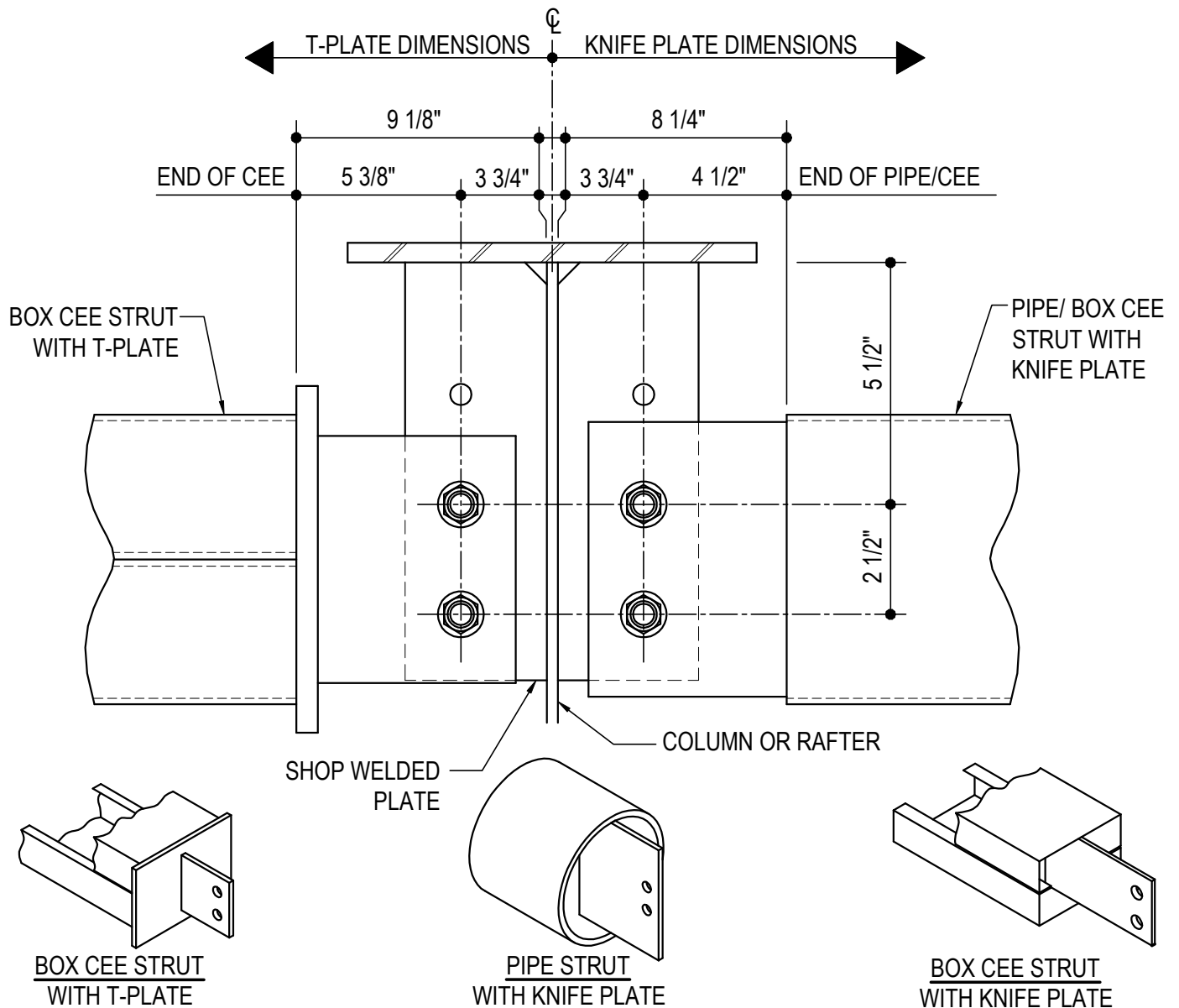

NOTE: USE (2) 1" X 3 1/4" A325 BOLTS H0640/NUTS H0330

2-BOLT 6" PIPE OR BOX STRUT AT WEB OF COLUMN/RAFTER

WITH LINERS AND 11" MIN. COLUMN/RAFTER
SEE PLANS & ELEVATIONS FOR MARK NUMBERS AND LOCATIONS

AK0161

Detailer Notes:

- 1) FOR PSC STANDARD PART MARKS AND THEIR LOCATIONS, SEE THE FABRICATED PARTS MANUAL AND THE DETAILING PROCEDURES MANUAL.
- 2) USE THIS DETAIL WHEN WALL AND/OR ROOF LINER INTERFERES WITH STRUT
- 3) USE THIS DETAIL WHEN BUILDING HAS FLUSH GIRTS WITH ROOF SLOPE GREATER THAN OR EQUAL TO 4:12

AK0165 - 2-BOLT 6" PIPE OR BOX STRUT AT WEB OF COLUMN/RAFTER (WITH PADDLE BRACE)

[Download the DWG file by clicking here.](#)

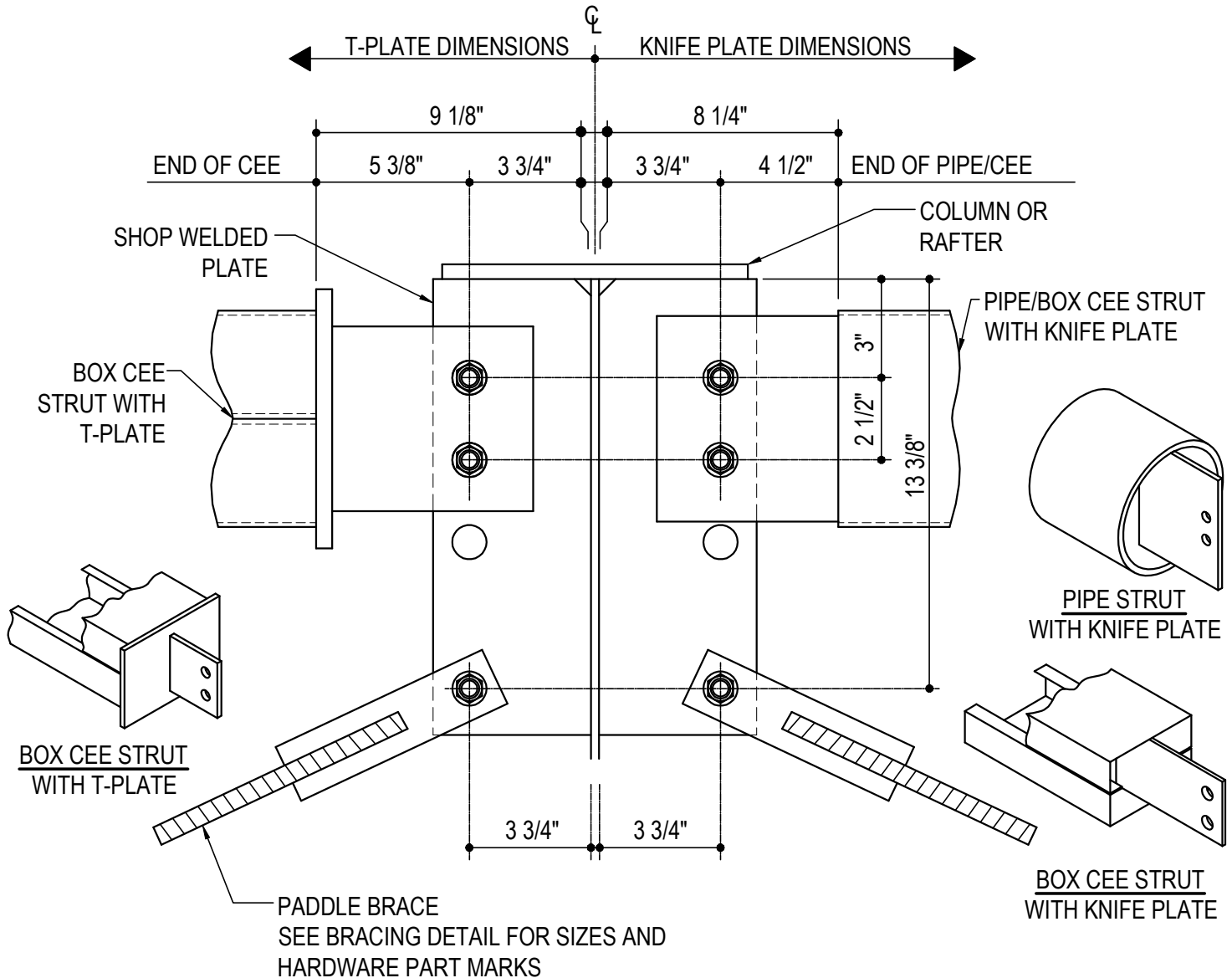

NOTE: USE (2) 1" X 3 1/4" A325 BOLTS H0640/NUTS H0330 AT STRUT CONNECTION

2-BOLT 6" PIPE OR BOX STRUT AT WEB OF COLUMN/RAFTER

WITH PADDLE BRACE

SEE PLANS & ELEVATIONS FOR MARK NUMBERS AND LOCATIONS

AK0165

Detailer Notes:

- 1) FOR PSC STANDARD PART MARKS AND THEIR LOCATIONS, SEE THE FABRICATED PARTS MANUAL AND THE DETAILING PROCEDURES MANUAL

AK0166 - 2-BOLT 6" PIPE OR BOX STRUT WITH TIERED PADDLE BRACING (STIFFENER CONNECTION)

[Download the DWG file by clicking here.](#)

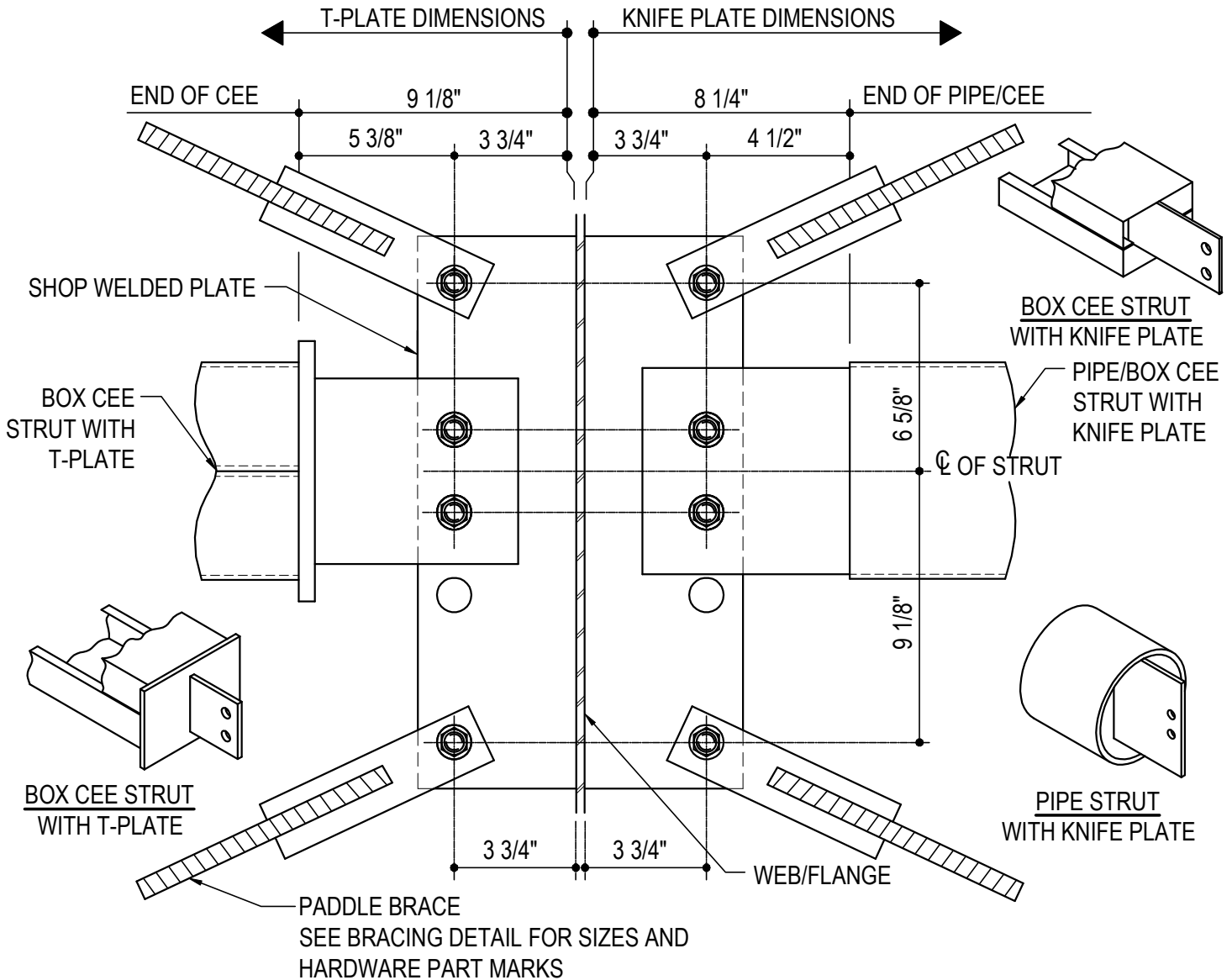

NOTE: USE (2) 1" X 3 1/4" A325 BOLTS H0640/NUTS H0330 AT STRUT CONNECTION

2-BOLT 6" PIPE OR BOX STRUT WITH TIERED PADDLE BRACING

STIFFENER CONNECTION

SEE PLANS & ELEVATIONS FOR MARK NUMBERS AND LOCATIONS

AK0166

Detailer Notes:

- 1) FOR PSC STANDARD PART MARKS AND THEIR LOCATIONS, SEE THE FABRICATED PARTS MANUAL AND THE DETAILING PROCEDURES MANUAL

AK0167 - 2-BOLT 6" PIPE OR BOX STRUT AT WEB WITH PADDLE BRACE (WITH LINER AT STIFFENER CONNECTION)

[Download the DWG file by clicking here.](#)

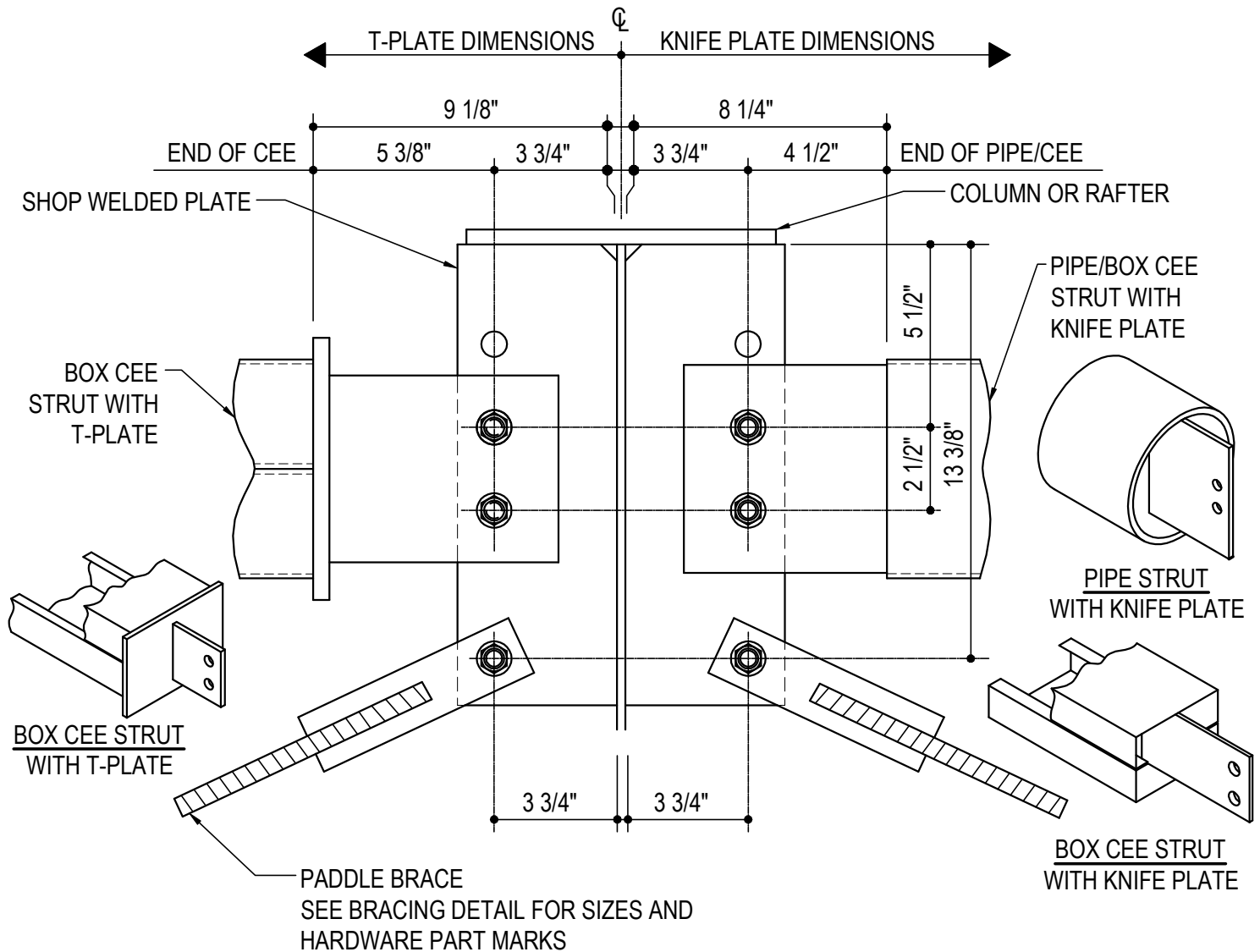

NOTE: USE (2) 1" X 3 1/4" A325 BOLTS H0640/NUTS H0330 AT STRUT CONNECTION

2-BOLT 6" PIPE OR BOX STRUT AT WEB WITH PADDLE BRACE

WITH LINER AT STIFFENER CONNECTION
SEE PLANS & ELEVATIONS FOR MARK NUMBERS AND LOCATIONS

AK0167

Detailer Notes:

- 1) FOR PSC STANDARD PART MARKS AND THEIR LOCATIONS, SEE THE FABRICATED PARTS MANUAL AND THE DETAILING PROCEDURES MANUAL.
- 2) USE THIS DETAIL WHEN WALL AND/OR ROOF LINER INTERFERES WITH STRUT
- 3) USE THIS DETAIL WHEN BUILDING HAS FLUSH GIRTS WITH ROOF SLOPE GREATER THAN OR EQUAL TO 4:12

AK0170 - 3-BOLT 6"/8" PIPE STRUT AT COLUMN/RAFTER (STIFFENER CONNECTION WITH 10" MIN. COLUMN/RAFTER)

[Download the DWG file by clicking here.](#)

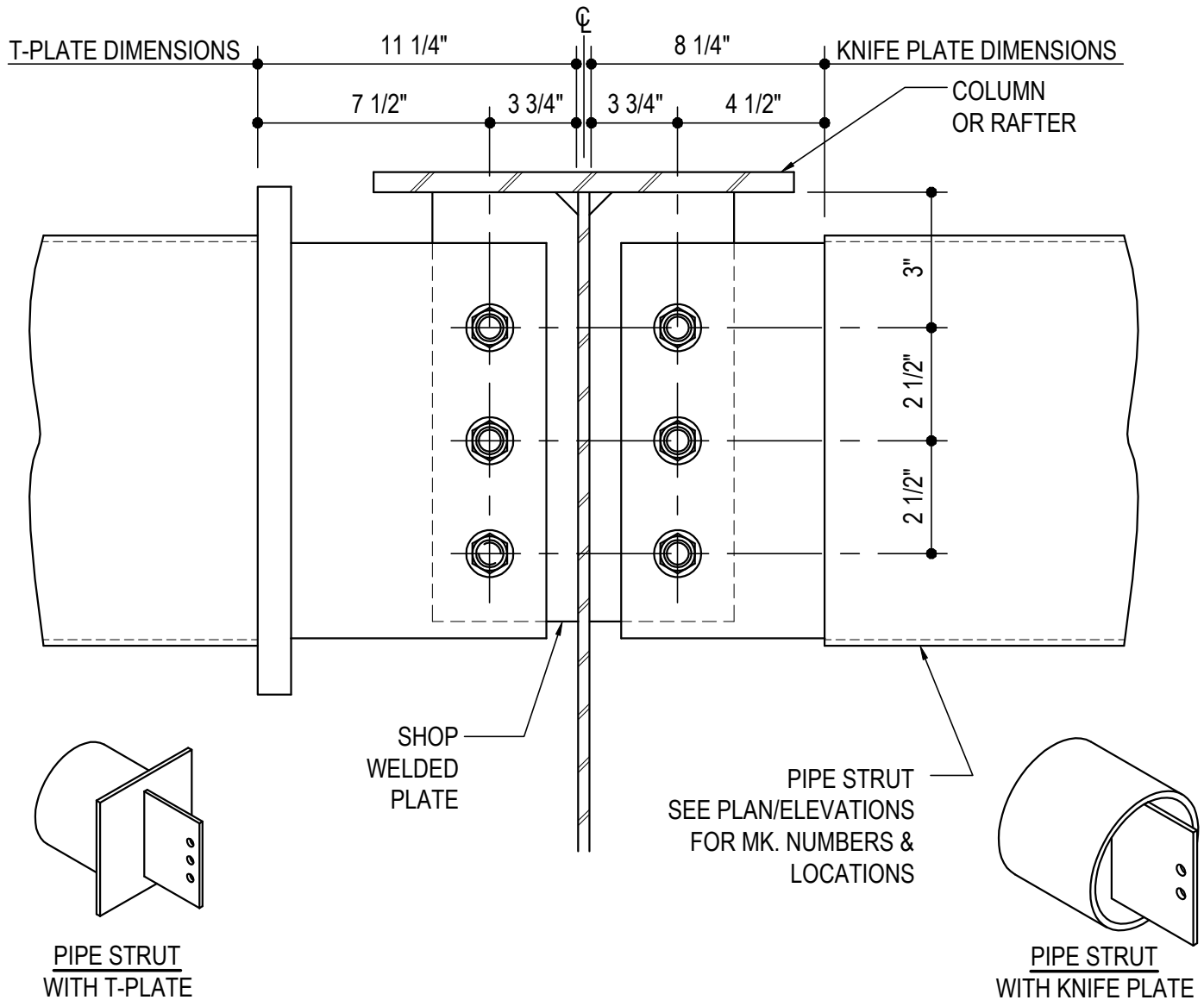

NOTE: USE (3) 1" X 3 1/4" A325 BOLTS H0640/NUTS H0330

3-BOLT 6"/8" PIPE STRUT AT COLUMN/RAFTER

STIFFENER CONNECTION WITH 10" MIN. COLUMN/RAFTER
SEE PLANS & ELEVATIONS FOR MARK NUMBERS AND LOCATIONS

AK0170

Detailer Notes:

- 1) FOR PSC STANDARD PART MARKS AND THEIR LOCATIONS, SEE THE FABRICATED PARTS MANUAL AND THE DETAILING PROCEDURES MANUAL

AK0175 - 3-BOLT 6"/8" PIPE STRUT AT WEB OF COLUMN/RAFTER (STIFFENER WITH PADDLE BRACE)

[Download the DWG file by clicking here.](#)

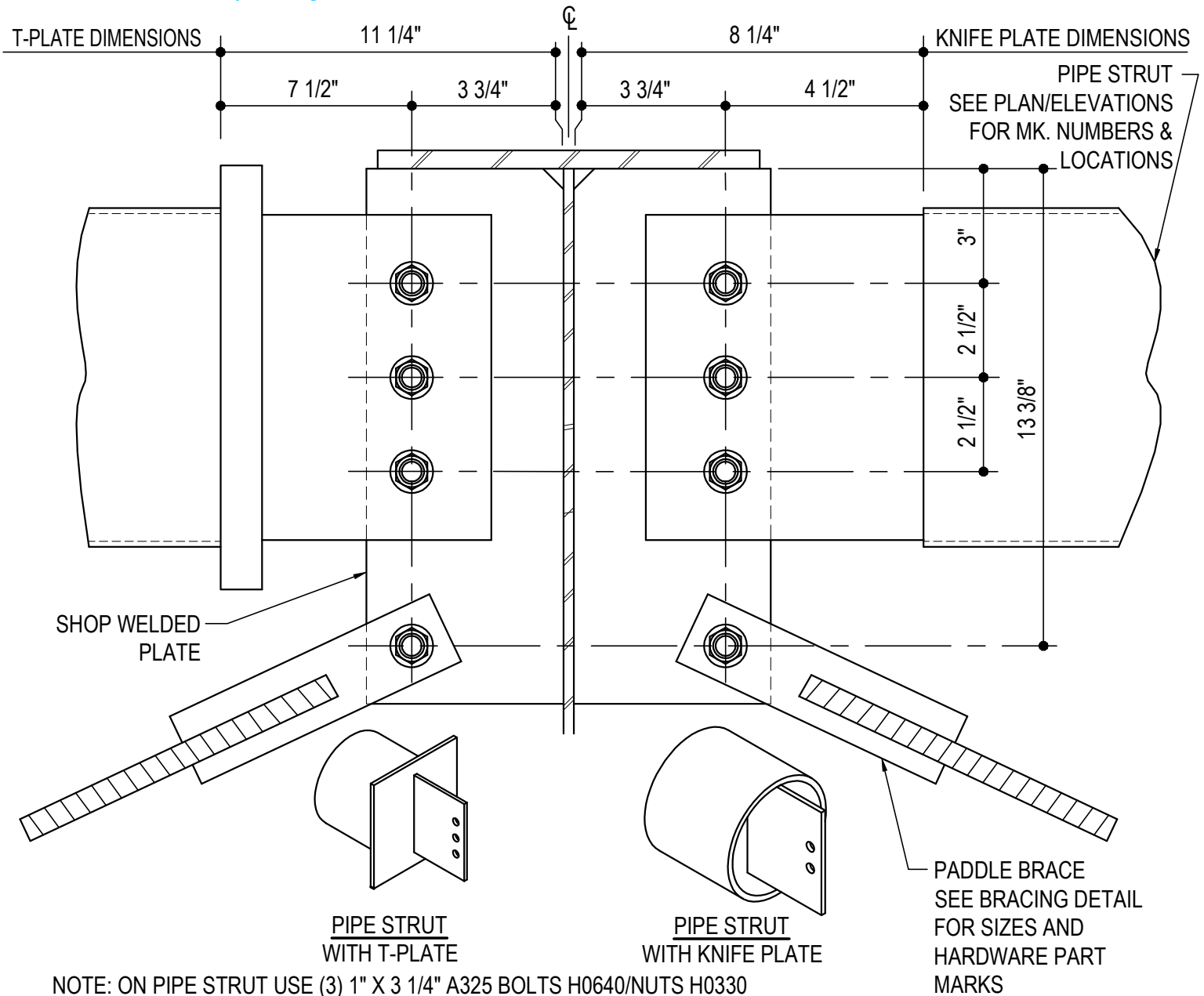

NOTE: ON PIPE STRUT USE (3) 1" X 3 1/4" A325 BOLTS H0640/NUTS H0330

3-BOLT 6"/8" PIPE STRUT AT WEB OF COLUMN/RAFTER

STIFFENER CONNECTION WITH PADDLE BRACE
SEE PLANS & ELEVATIONS FOR MARK NUMBERS AND LOCATIONS

AK0175

Detailer Notes:

- 1) FOR PSC STANDARD PART MARKS AND THEIR LOCATIONS, SEE THE FABRICATED PARTS MANUAL AND THE DETAILING PROCEDURES MANUAL

AK0176 - 3-BOLT 6"/8" PIPE STRUT WITH TIERED PADDLE BRACING (STIFFENER CONNECTION)

[Download the DWG file by clicking here.](#)

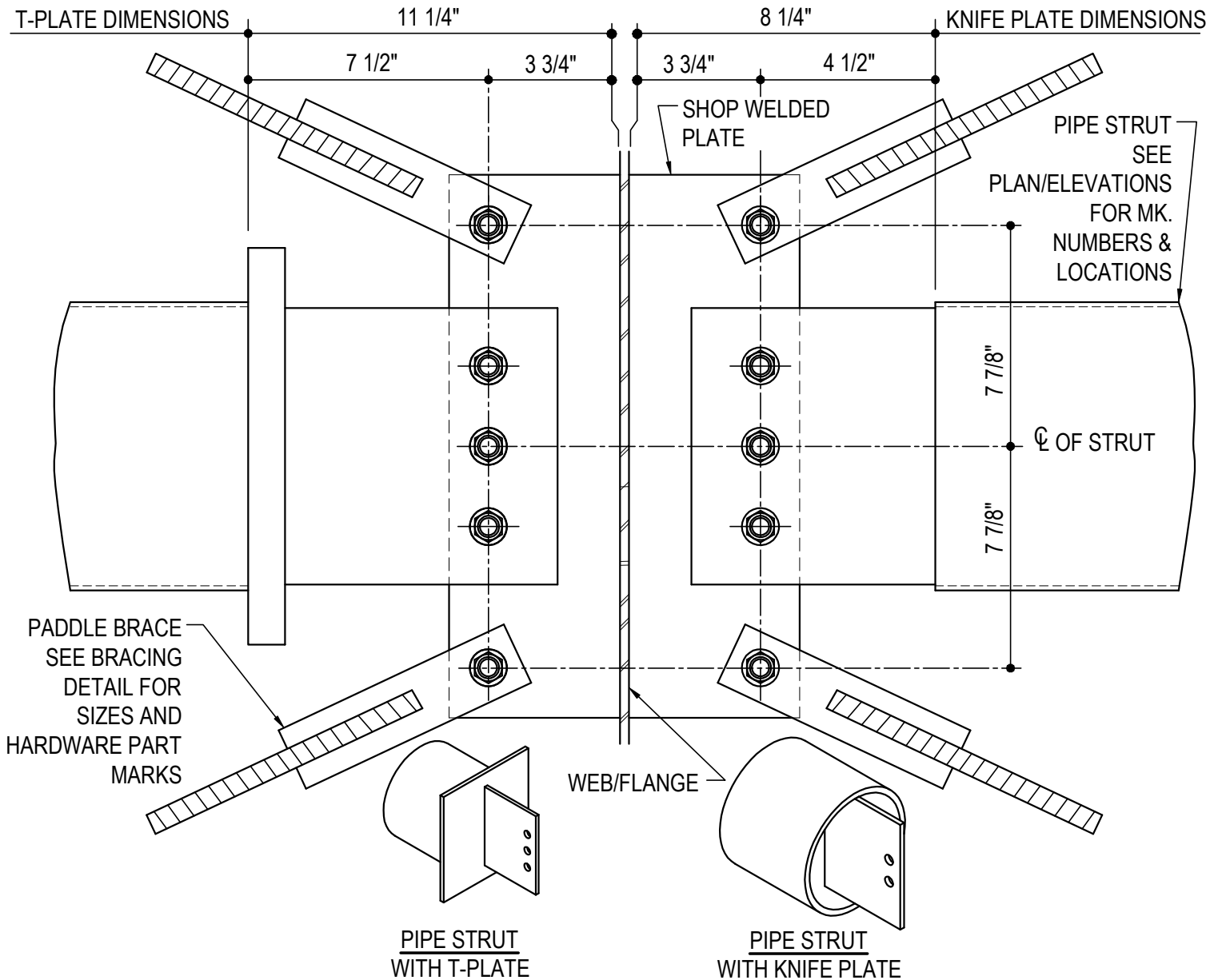

NOTE: ON PIPE STRUT USE (3) 1" X 3 1/4" A325 BOLTS H0640/NUTS H0330

3-BOLT 6"/8" PIPE STRUT WITH TIERED PADDLE BRACING

STIFFENER CONNECTION

SEE PLANS & ELEVATIONS FOR MARK NUMBERS AND LOCATIONS

AK0176

Detailer Notes:

- 1) FOR PSC STANDARD PART MARKS AND THEIR LOCATIONS, SEE THE FABRICATED PARTS MANUAL AND THE DETAILING PROCEDURES MANUAL

AK0177 - 2-BOLT STRUT AT 8" ENDWALL (6" PIPE OR BOX CEE STRUT)

[Download the DWG file by clicking here.](#)

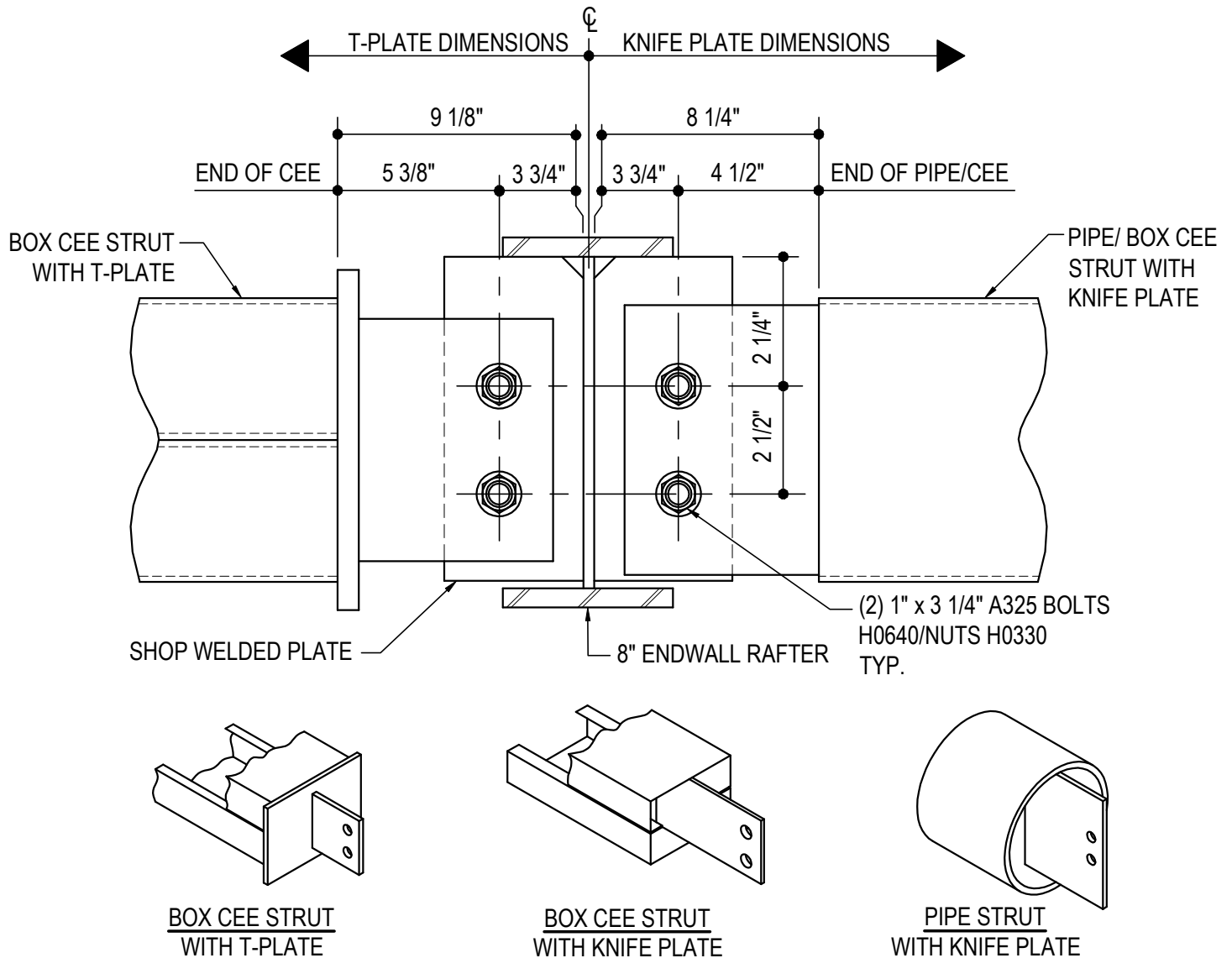

2-BOLT STRUT AT 8" ENDWALL (6" PIPE OR BOX CEE STRUT)

SEE PLANS & ELEVATIONS FOR MARK NUMBERS AND LOCATIONS
REFERENCE ERECTOR NOTE FOR TYPICAL WASHER REQUIREMENTS

AK0177

Detailer Notes:

- 1) FOR PSC STANDARD PART MARKS AND THEIR LOCATIONS, SEE THE FABRICATED PARTS MANUAL AND THE DETAILING PROCEDURES MANUAL

AK0300 - STRUT PURLIN DETAIL

[Download the DWG file by clicking here.](#)

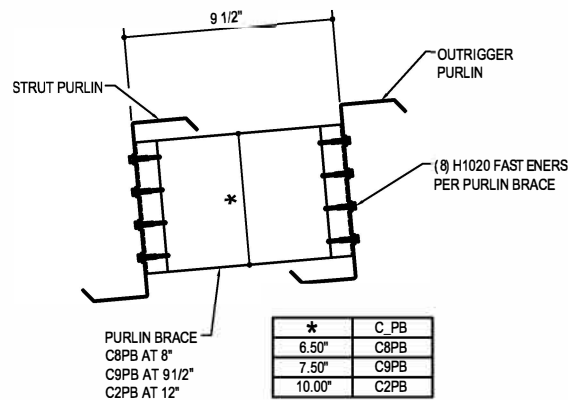
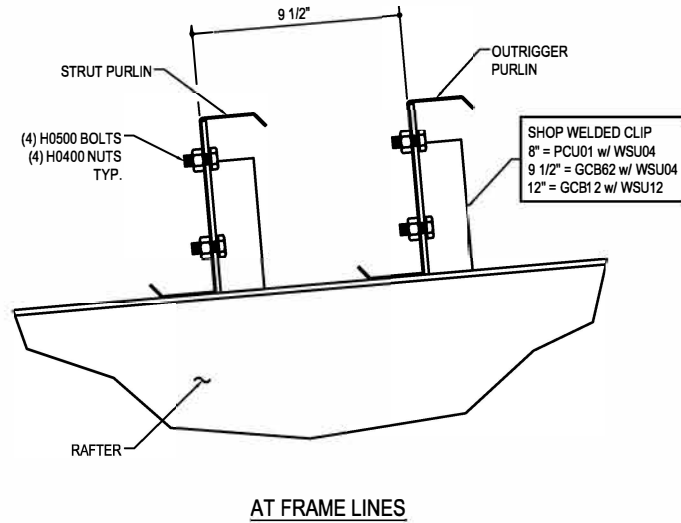

BETWEEN FRAME LINES
(SEE ROOF PLAN FOR LOCATIONS OF C_PB PURLIN BRACE)

STRUT PURLIN DETAIL

SEE PLANS & ELEVATIONS FOR MARK NUMBERS AND LOCATIONS
REFERENCE ERECTOR NOTE FOR TYPICAL WASHER REQUIREMENTS

AK0300

Detailer Notes:

- 1) N/A