

INTERIOR DETAILS

BB0050 - WELDED CLIP @ END FRAME DETAIL

BB0055 - WELDED CLIP @ INTERIOR FRAME DETAIL

BB0071 - CF EW RAFTER AT NON-COLUMN BRACE LOCATIONS

BB0100 - SINGLE CF EW RAFTER AT COLUMN LOCATIONS

BB0110 - PURLIN CONN. @ C. F. RAFTER LAP

BB0050 - WELDED CLIP @ END FRAME DETAIL

[Download the DWG file by clicking here.](#)

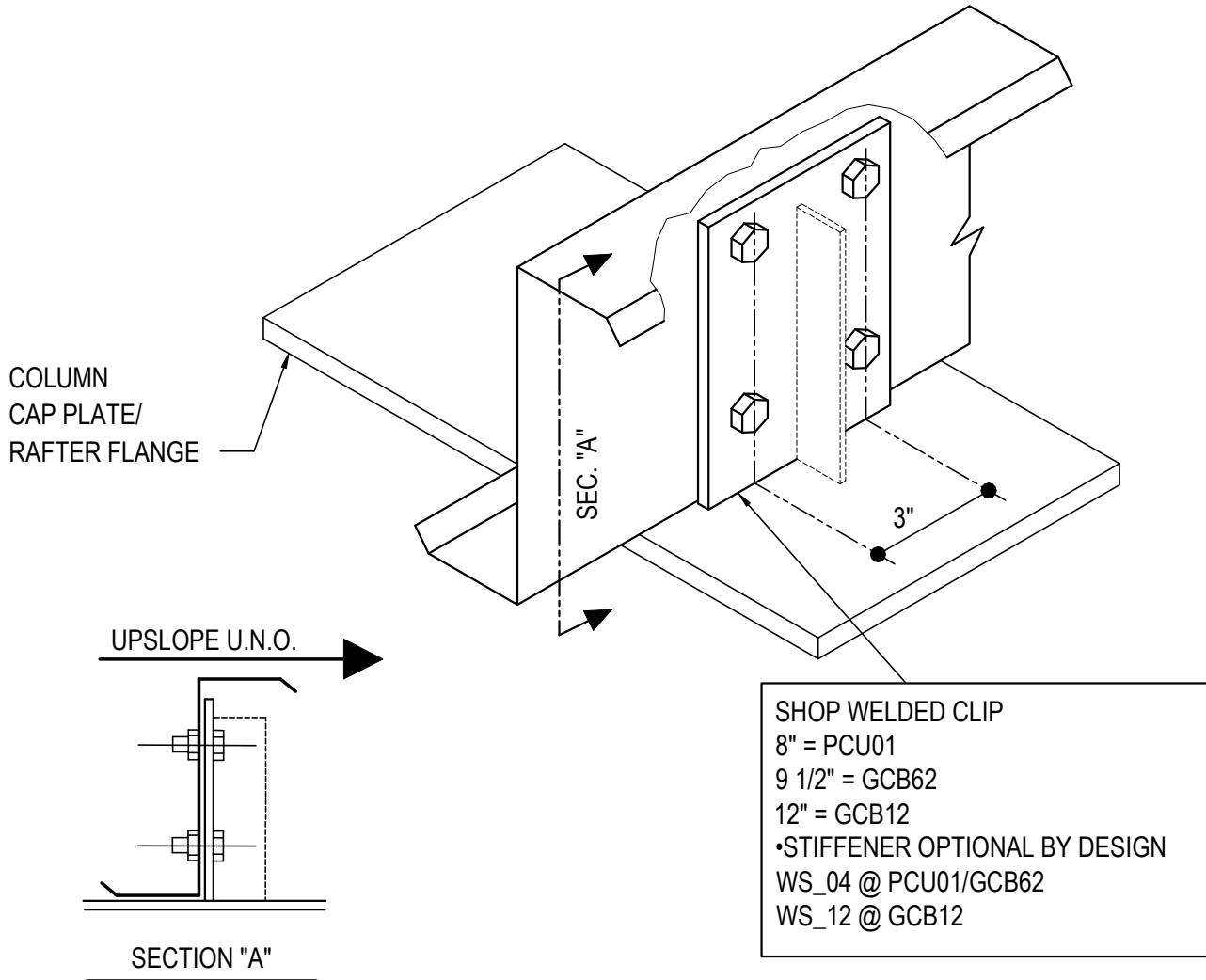

WELDED CLIP @ END FRAME

USE (4) 1/2" x 1 1/4" A307 BOLTS H0500/NUTS H0400 U.N.O.
 REFERENCE ERECTOR NOTE FOR TYP. WASHER REQUIREMENTS

BB0050

Detailer Notes:

- 1) N/A

BB0055 - WELDED CLIP @ INTERIOR FRAME DETAIL

[Download the DWG file by clicking here.](#)

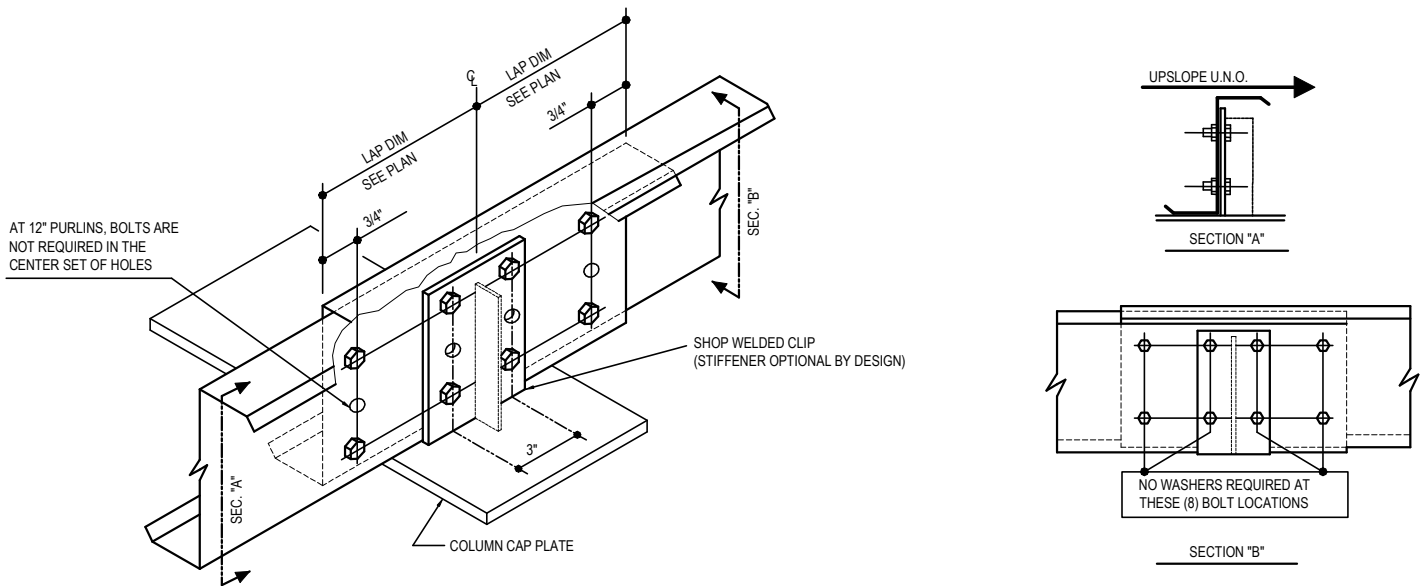

WELDED CLIP @ INTERIOR FRAME

USE (8) 1/2" x 1 1/4" A307 BOLTS H0500/NUTS H0400 U.N.O.

BB0055

Detailer Notes:

- 1) SHOP WELDED PURLIN CLIPS: 8" = PCU01, 9 1/2" = GCB62, 12" = GCB12
- 2) OPTIONAL PURLIN CLIP STIFFENER BY DESIGN: WS_04 @ PCU01 / GCB62, WS_12 @ GCB12

BB0071 - CF EW RAFTER AT NON-COLUMN BRACE LOCATIONS

[Download the DWG file by clicking here.](#)

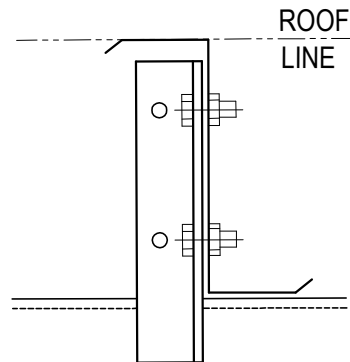
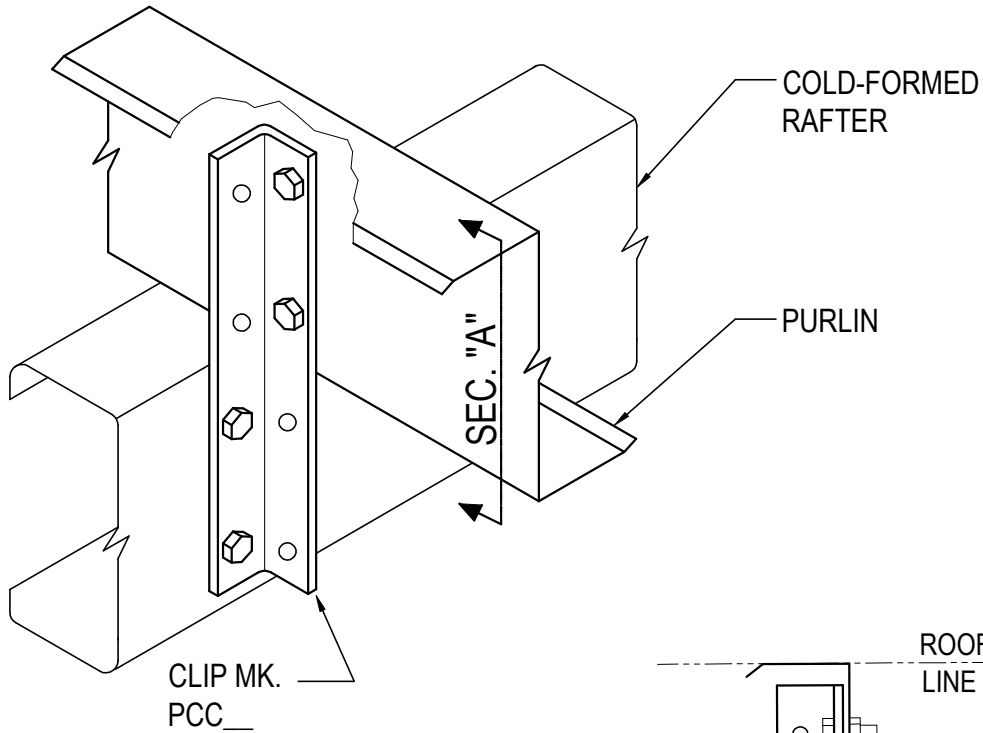

		PURLIN DEPTH		
		8"	9.5"	12"
RAFTER DEPTH	8"	PCC01	PCC13	PCC02
	12"	PCC02	PCC14	PCC05

SECTION A

PURLIN CONN @ C.F. RAFTER

USE (4) 1/2" X 1 1/4" A307 BOLT H0500/NUT H0400 U.N.O.
REFERENCE ERECTOR NOTE FOR TYP. WASHER REQUIREMENTS

BB0071

Detailer Notes:

- 1) N/A

BB0100 - SINGLE CF EW RAFTER AT COLUMN LOCATIONS

[Download the DWG file by clicking here.](#)

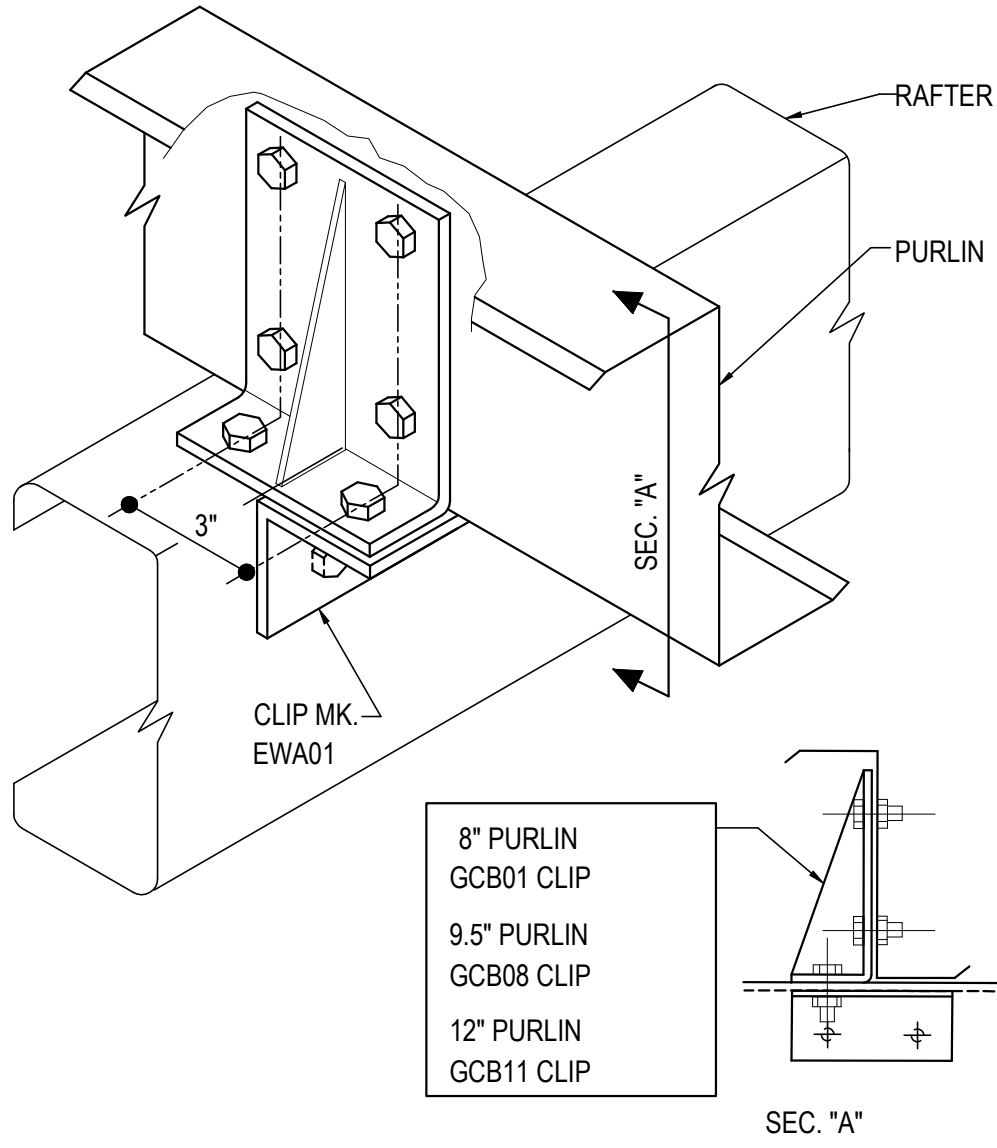

EW PURLIN @ C.F. RAFTER

USE (8) 1/2" X 1 1/4" A307 BOLT H0500/NUT H0400 U.N.O.
REFERENCE ERECTOR NOTE FOR TYP. WASHER REQUIREMENTS

BB0100

Detailer Notes:

- 1) N/A

BB0110 - PURLIN CONN. @ C. F. RAFTER LAP

[Download the DWG file by clicking here.](#)

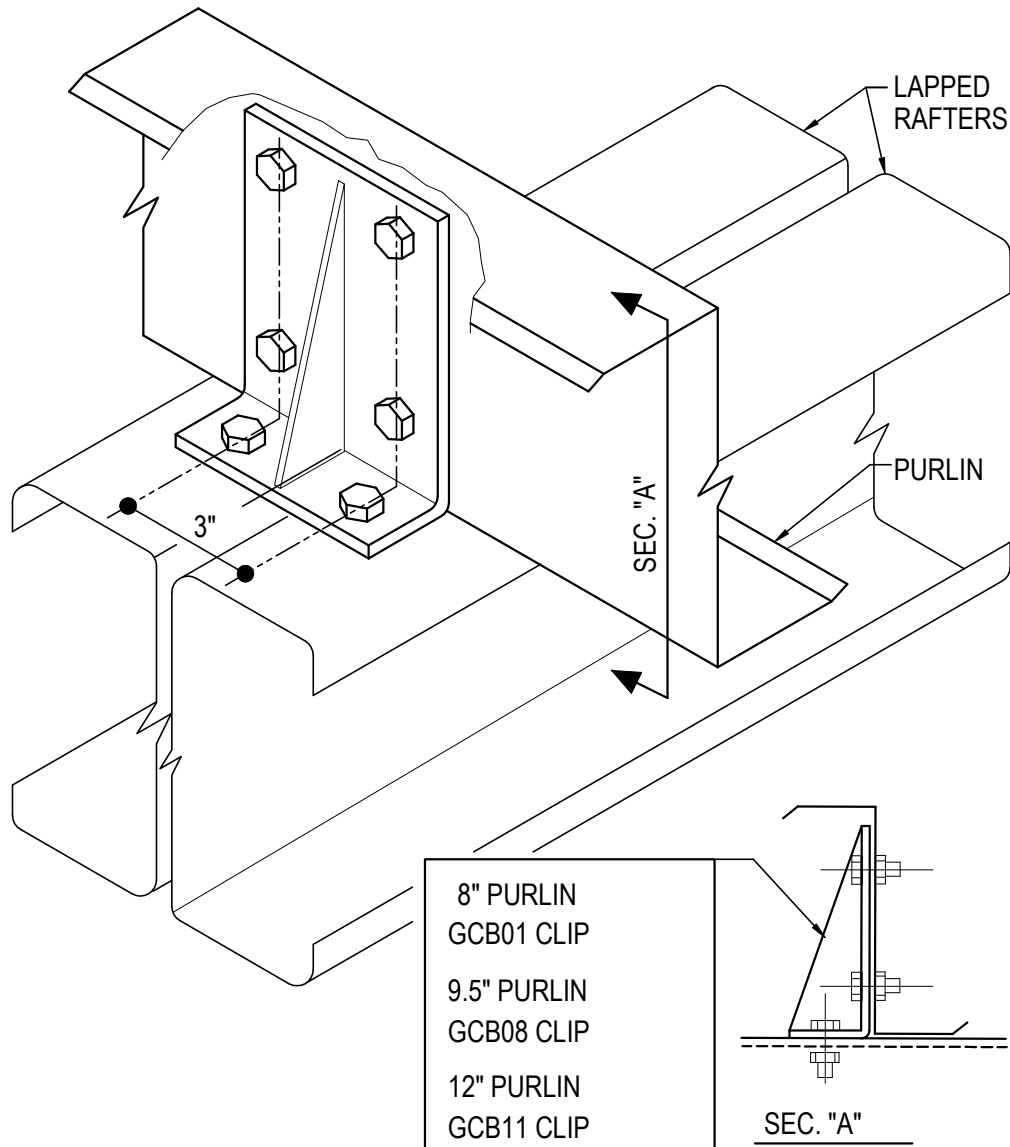

PURLIN CONN. @ C. F. RAFTER LAP

USE (6) 1/2" X 1 1/4" A307 BOLT H0500/NUT H0400 U.N.O.
REFERENCE ERECTOR NOTE FOR TYP. WASHER REQUIREMENTS

BB0110

Detailer Notes:

- 1) N/A